

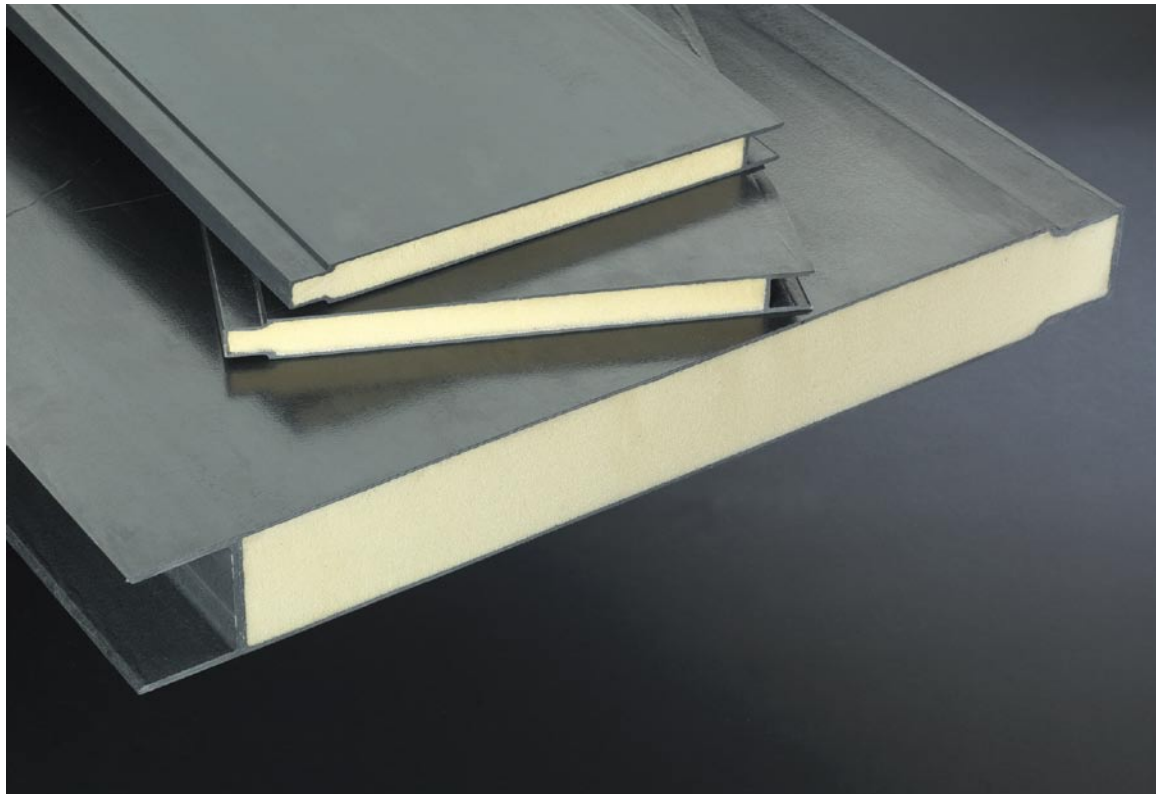

DURA SHIELD[®]

FIBERGLASS FOAM CORE BUILDING PANELS

GEF Incorporated





Fiberglass Foam Core Building Panels



DURASHIELD® panels are used as plant roofs and chemical tank covers in corrosive environments, such as the covers (16,800 s.f.) over anaerobic digester units pictures above.



Airtight enclosure for Dow Chemical protects workers in adjacent areas against accidental escape of phosgene gas.



Compaq Computer chose a foam core panel building to assure RF/EMI compliance for attenuation.

Features

The DURASHIELD® panel is a tongue-and-groove fiberglass pultruded panel comprised of a pultruded skin over a foam core. The panel provides these features:

- Integral Insulation
- Corrosion Resistant
- Strong
- Transparent to Electromagnetic Emissions
- Lightweight
- Low in Conductivity
- Flame Retardant

Sizes

DURASHIELD® panels are available in 1" x 12" and 3" x 24" sizes. Special thicknesses or widths are possible if the quantity warrants. The panels can be produced in any length that is practical. Typical lengths would be in the 12' to 32' range.

Materials of Construction

The pultruded fiberglass skin is available in either an isophthalic polyester or a vinyl ester resin. Both resin systems provide flame retardance (UL94 VO). The vinyl ester is utilized in extreme corrosive applications. A synthetic surfacing veil is incorporated into the skin to improve weathering, corrosion resistance and resistance to degradation from ultraviolet rays. Resistance to weathering can be further enhanced by the application of a polyurethane paint. The core material is a rigid closed-cell urethane foam. The ends of the panels must be encapsulated or coated with a resin similar to the skin resin to maintain the corrosion and weather resistant qualities of the total panel.

Applications

DURASHIELD® panels are designed to be used as walls, roofs and covers. Typical applications are:

- Radar, Microwave, Radio and TV Antenna Enclosures
- Enclosures for Electrical Equipment
- Enclosures of Chemical Processing Operations
- Buildings for EMI Testing (Computer Testing)
- Chemical Pit Covers
- Roofs on Wet-End Pulp and Paper Manufacturing
- Modular Buildings

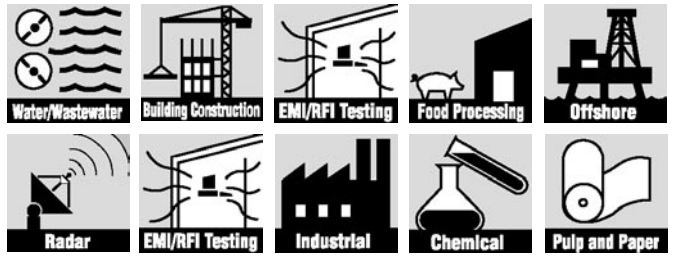

Roofing and Siding Load Tables

1" Panel Allowable Uniform Load (psf)

SPAN (ft.)	@Δ=span/60			@Δ=span/120			@Δ=span/180		
	Δ (IN.)	Siding	Roofing	Δ (IN.)	Siding	Roofing	Δ (IN.)	Siding	Roofing
4	.8	*138	*136	.4	*138	*136	.27	90	88
5	1.0	*88	*86	.5	72	70	.33	40	38
6	1.2	*61	*59	.6	38	36	.40	20	18
7	1.4	45	43	.7	22	20	.47	12	10
8	1.6	32	30	.8	14	12	.53	8	6
9	1.8	22	20	.9	8	6	.60	4	2
10	2.0	14	12	1.0	6	4	—	—	—
11	2.2	10	8	1.1	4	2	—	—	—
12	2.4	8	6	—	—	—	—	—	—

3" Panel Allowable Uniform Load (psf)

SPAN (ft.)	@Δ=span/60			@Δ=span/120			@Δ=span/180		
	Δ (IN.)	Siding	Roofing	Δ (IN.)	Siding	Roofing	Δ (IN.)	Siding	Roofing
6	1.2	*340	*336	.6	289	285	.4	190	186
7	1.4	*246	*242	.7	188	184	.47	124	120
8	1.6	*189	*185	.8	129	125	.53	85	81
9	1.8	*150	*146	.9	93	89	.60	61	57
10	2.0	*121	*117	1.0	69	65	.67	45	41
11	2.2	100	96	1.1	53	49	.73	35	31
12	2.4	84	80	1.2	41	37	.80	27	23
13	2.6	67	63	1.3	33	29	.87	22	18
14	2.8	55	51	1.4	27	23	.93	18	14
15	3.0	45	41	1.5	22	18	1.00	15	11
16	3.2	38	34	1.6	18	14	1.07	12	8
17	3.4	32	28	1.7	16	12	1.13	10	6
18	3.6	27	23	1.8	13	9	1.20	9	5
19	3.8	23	19	1.9	11	7	1.27	8	4
20	4.0	20	16	2.0	10	6	1.33	7	3

*Controlled by stress with a factor of safety of 1.50

PERFORMANCE: These tables are offered as a guide only. The effects of sustained impact or dynamic loads, the particular corrosive environment and/or elevated temperatures have not been factored into these tables. Please consult the Strongwell *Design Manual* for guidance and design considerations when applications include any of the above effects.

Mechanical Properties (nominal)

Property	1" Panel	3" Panel
Flexural Strength (psi)	1,750	869
Flexural Modulus (10 ⁶ psi)	.2	.17
Short Beam Shear (psi)	113	90
Coefficient of Thermal Exp. (10 ⁻⁶ in/in/F°)	5.2	5.2
Pullout Test (pull through) (lbs.)		
• Std. washer (1" dia. w/ 3/8" hole)	650	730
• Fender washer (2" dia. w/ 1/2" hole)	1,300	1,620
Crush Test (6" x 6" load plate) (lbs.)	5,600	6,750
Crush Test (full width) (lbs.)		
• 1" dia. bar	5,200	
• 2-1/2" dia. bar		18,800

Physical Properties (nominal)

Property	1" Panel	3" Panel
Weight (lbs/linear ft)	1.99	7.85
Panel Width (in.)	12	24
'R' Factor	7	21
Foam Density (#/cu ft)	4	4
Minimum thickness of fiberglass composites skin (in)	.060	.088
Flame Spread Rating		
ASTM E-84	Max 25	Max 25
Water Absorption	<.3% if properly sealed	<.3% if properly sealed

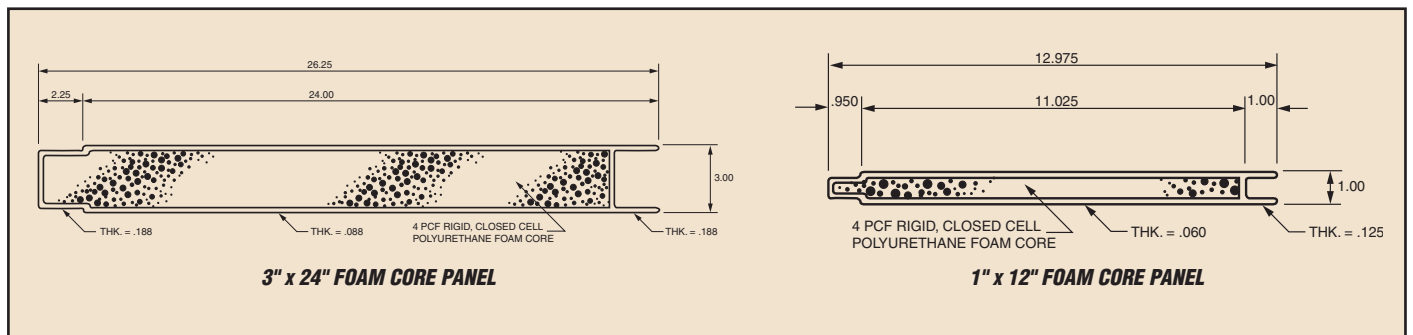

Product consistency assures trouble free assembly.

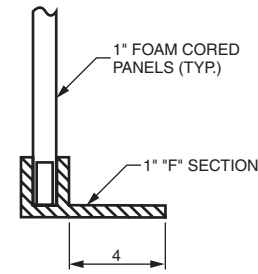

SECTION / BASE

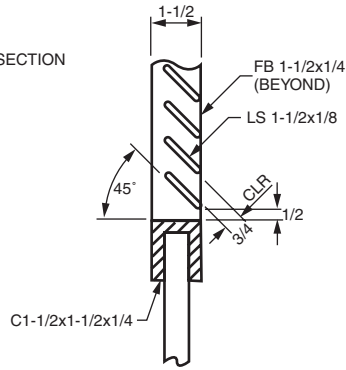

SECTION / WINDOW LOUVERS

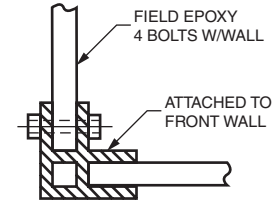

SECTION / WALL CORNER

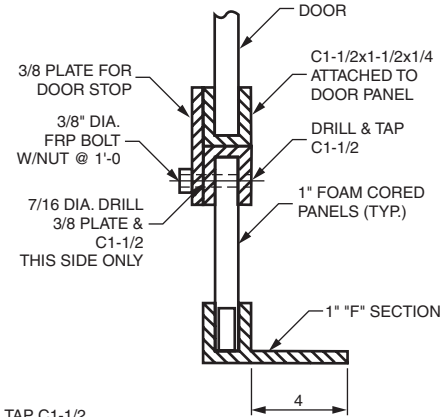

SECTION / DOOR FRAMING

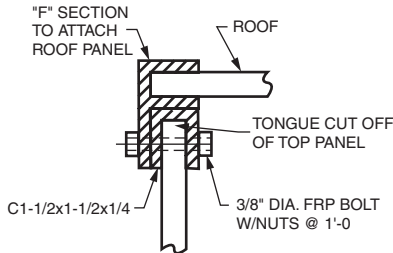

SECTION / ROOF

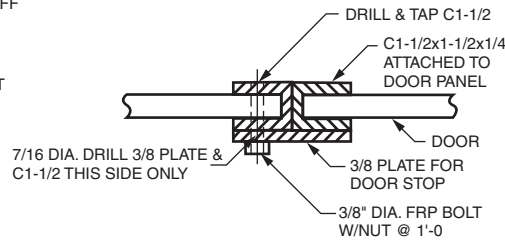

SECTION / DOOR FRAMING

Supporting Fiberglass Structural Shapes

DURASHIELD® panels are made for use with Strongwell's EXTREN® line of structural shapes. EXTREN® is available in more than 100 standard shapes. Typical additional supporting shapes are shown below.

Use	1" Panel Supporting Shapes Shape Description	3" Panel Supporting Shapes Shape Description
Section/Base	5-1/2" x 1-1/2" x 1/4" F Section	Standard EXTREN® Angle
Corner Post	3-1/2" x 1/4" Custom Corner Post	Standard EXTREN® Angles Inside & Outside
Roof Joiner	5-1/2" x 1-1/2" x 1/4" F Section	90° Custom Angle
Door Framing	1-1/2" x 1-1/2" x 1/4" EXTREN® Channel	3-1/2" x 2" x 7/32" EXTREN® Channel
Window Louvers	1-1/2" x 1-1/2" x 1/4" EXTREN® Channel	3-1/2" x 2" x 7/32" EXTREN® Channel
Fasteners	3/8" dia. FIBREBOLT® Stud & Nut Stainless Steel (optional)	1/2" dia. FIBREBOLT® Stud & Nut Stainless Steel (optional)



GEF INCORPORATED

6497 WINFIELD ROAD • WINFIELD, WEST VIRGINIA 25213

304/755-1600 • 304/755-3150 FAX • 800/784-0529 TOLL FREE

www.gefinc.com